

## GEARBOXES

ZF

ENGINE FLYWHEEL  
PTO - SAE 1

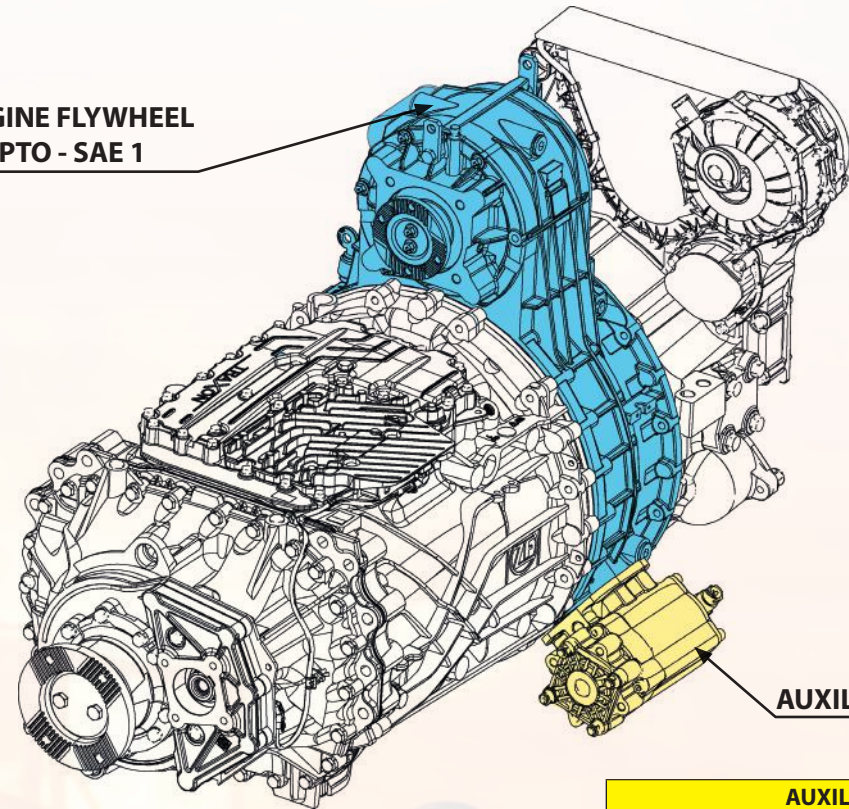

AUXILIARY PTO S296

AUXILIARY PTO S296			
Main PTO output ratio:	1:1,02	1:1,27	1:1,52
Torque Nm:	270		
PTO output ratio:	1:1,01	1:1,01	1:1,20
PTO rotation (view from rear)	↻ (Opposite Engine)		

ALLISON 4000

ENGINE FLYWHEEL  
PTO - SAE 1

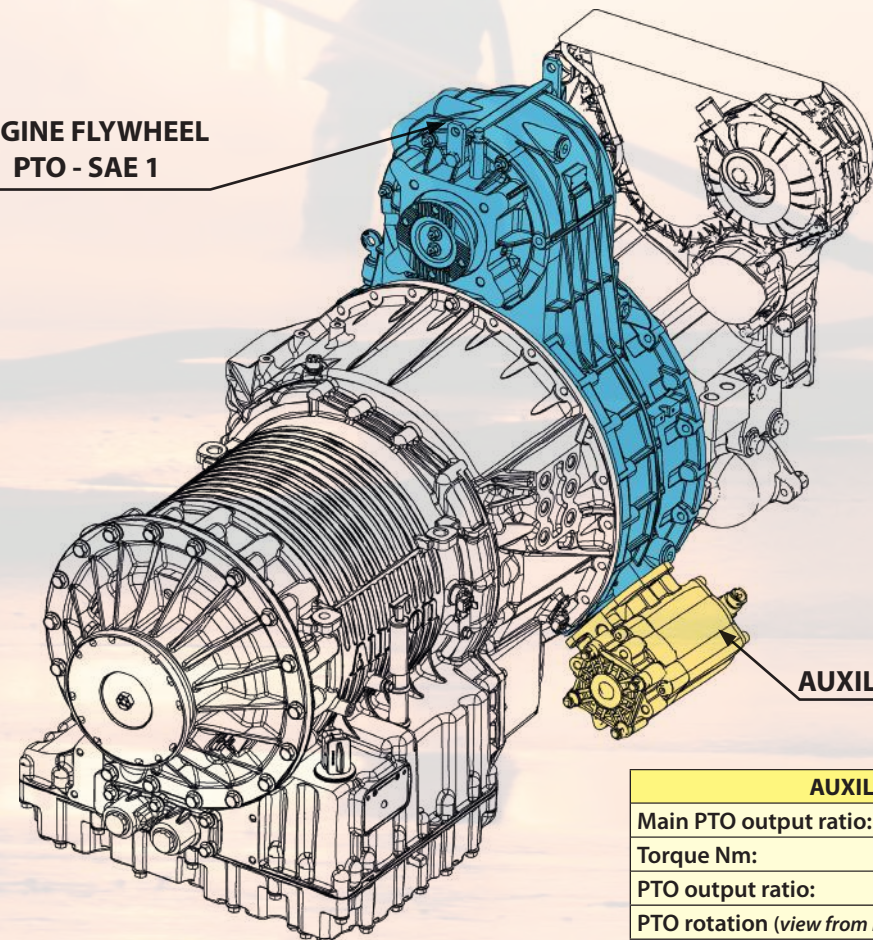

AUXILIARY PTO S296

AUXILIARY PTO S296			
Main PTO output ratio:	1:1,02	1:1,27	1:1,52
Torque Nm:	270		
PTO output ratio:	1:1,01	1:1,01	1:1,20
PTO rotation (view from rear)	↻ (Opposite Engine)		

# INTERPUMP HYDRAULICS

Via A. Mingozzi, 6 • 40012 Calderara di Reno (BO) • T +39 051 6460511 - F +39 051 6460560 • www.interpumphydraulics.com



www.hydrocar.com



www.munciepower.com



www.pzbitaly.com



www.takarada.com.br



www.hspenta.it



Santiago Del Chile  
Concepción  
Antofagasta  
www.hydrocar.cl



Hosur (Tamil Nadu)  
Rudrapur (Uttarakhand)  
www.interpumphydraulicsindia.com



Wuxi (Jiangsu)  
www.iph.net.cn



Jabel Ali  
(Dubai)  
www.interpump.ae



Brie Comte Robert (Paris)  
Flévy (Metz)  
www.interpumphydraulics.com



Lima  
www.interpumphydraulics.com



Meinerzhagen  
(Nordrhein-Westfalen)  
www.interpumphydraulics.com



Kingswinford  
West Midlands  
(England)  
www.interpumphydraulicsuk.com

Rev. 00 09/2016 • MHDEPDEE001

Layout & Graphic Design: Studio '80 (BO) ITALY

A member of INTERPUMP  
GROUP

INTERPUMP HYDRAULICS S.p.A.  
Via A. Mingozzi, 6 • 40012 Calderara di Reno (BO) - T +39 051 6460511 • F +39 051 6460560 • www.interpumphydraulics.com



# EFP-1

## Engine Flywheel Pto SAE 1

# New

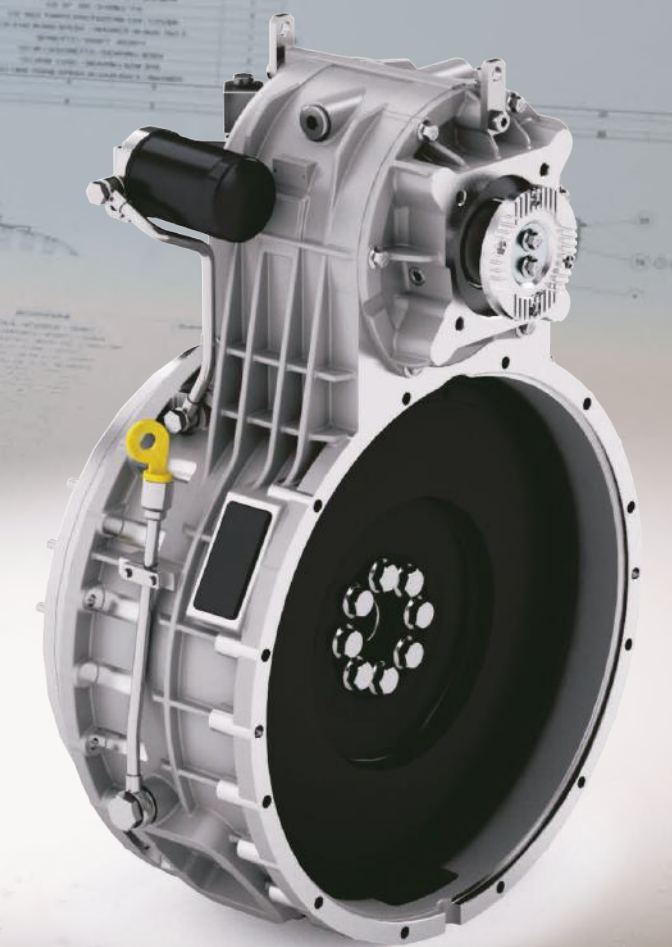





### PTO FOR HEAVY DUTY APPLICATIONS (100% OF ENGINE AVAILABLE TORQUE)

- Main applications are:
- fire-fighting (including pump & roll function),
  - refrigerator (cooler) vehicle
  - concrete mixer,
  - sewer cleaner,
  - snowplough,
  - drilling devices,
  - other.

### EASY TO FIT

The PTO EFP-1 is so easy to adapt that is easily suitable to be installed onto the following transmissions (manual, automated and fully automatic) and related engines:

- ZF,
- ALLISON (series 3000/4000),
- EATON,
- DAIMLER,
- VOLVO,
- TATA,
- ISUZU,
- HINO,
- NISSAN,
- FUSO,
- HYUNDAI,
- other.

### TECHNICAL SPECIFICATIONS

PTO clutch engagement limit conditions: 1000 r.p.m. / 2500 Nm / 262 kW  
 1500 r.p.m. / 1650 Nm / 262 kW  
 2000 r.p.m. / 1250 Nm / 262 kW

PTO output Torque: 2500 Nm / ratio 1:1,02  
 2000 Nm / ratio 1:1,27  
 1600 Nm / ratio 1:1,56

The max Power has to be considered as continuous use (392 kW max).

### FUNCTIONS

- Engine dependent pto;
- pto usage both with standing still vehicles as well as in mobile conditions (pump and roll);
- pto mounting position between engine and gearbox;
- pto output at 12 O'clock (from 11 up to 1 O'Clock - see pictures);
- assembling without any "special" or dedicated tool.

### OPTIONS

- Pto output engagement control, hot-shift (clutch), constant drive and hydraulic shifting (engine off);
- pre-arrangement for external oil cooler;
- temperature control option;
- oil level inspection;
- pto output sensor speed;
- auxiliary pto window opening located at 4 and 8 O'clock to avoid chassis collision 300 Nm ratio 1:1,32;
- oil cooler (air/oil);
- no residual clutch drag (active brake function).

### TECHNICAL SPECIFICATIONS

Unit through torque (to rear axle):  
 - as indication and reference 4000 Nm (max.); 530 kW - 720 HP (max).

### VEHICLES INSTALLATIONS

Max. engine speed: 2500 r.p.m  
 Max. operating angle of the vehicle: - forward / rearward: 17° (30%),  
 - right / left: 17° (30%).

### FLANGE OUTPUT

PTO output: - pump SAE C 4 bolts,  
 - flange 120 ISO 8667 (XS),  
 - flange 150 ISO 8667 (XS).

### MOUNTING POSITIONS

STANDARD: h12

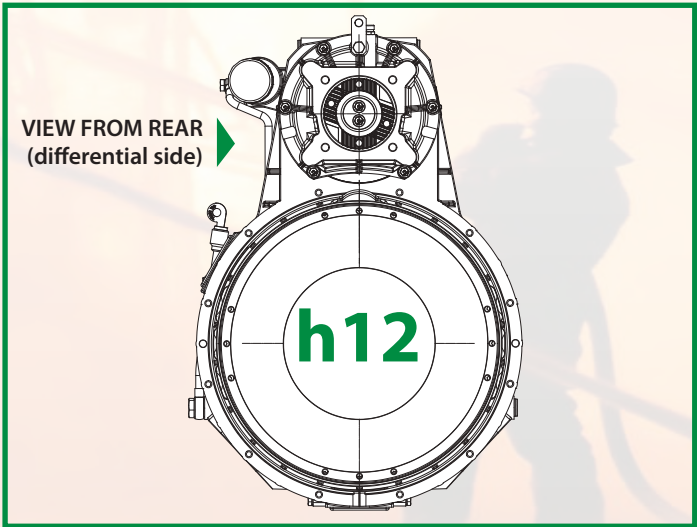

OPTIONAL: +30° or -30°

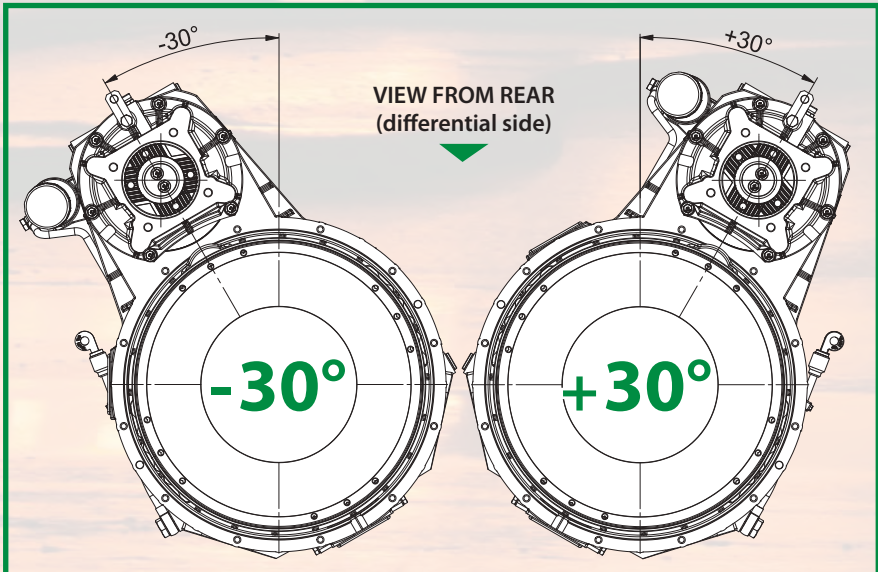

### DIMENSIONS

### VERSION WITH DAMPER

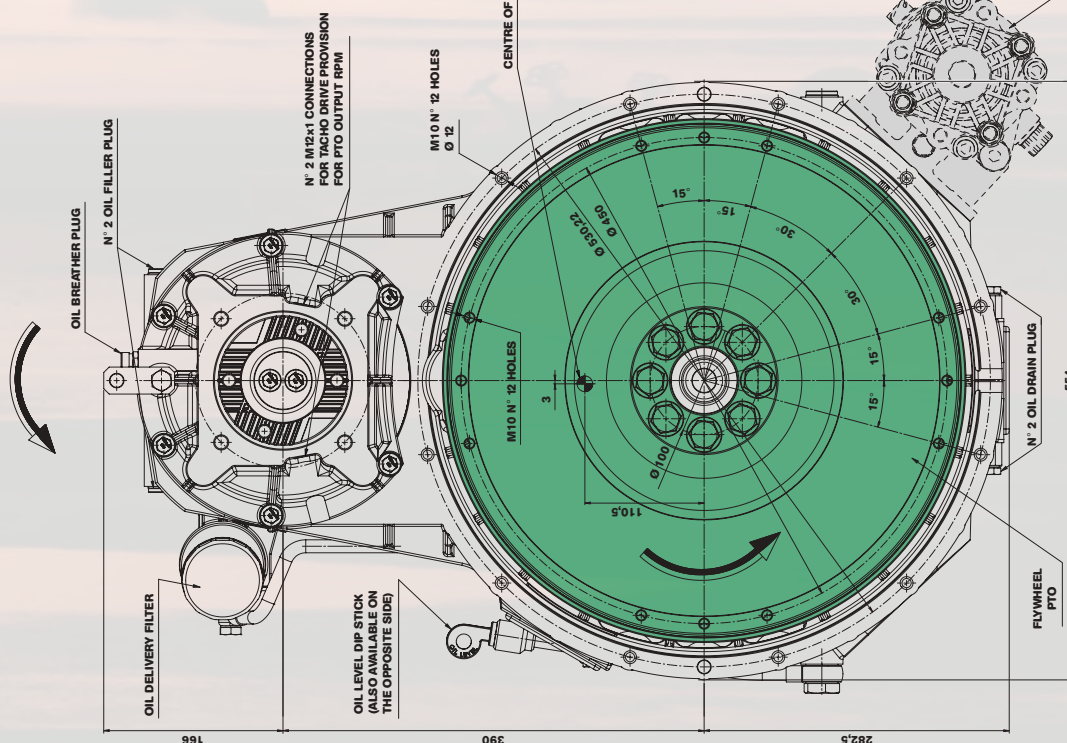
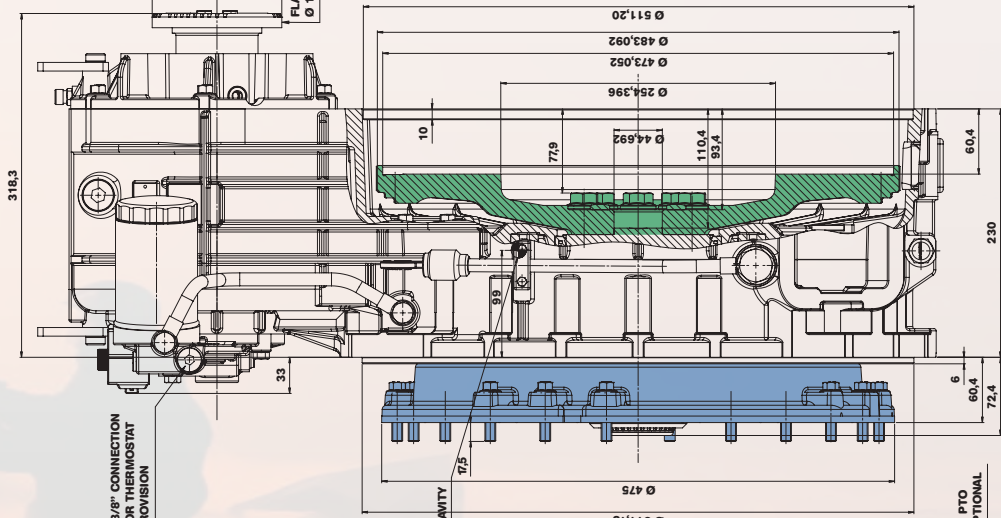
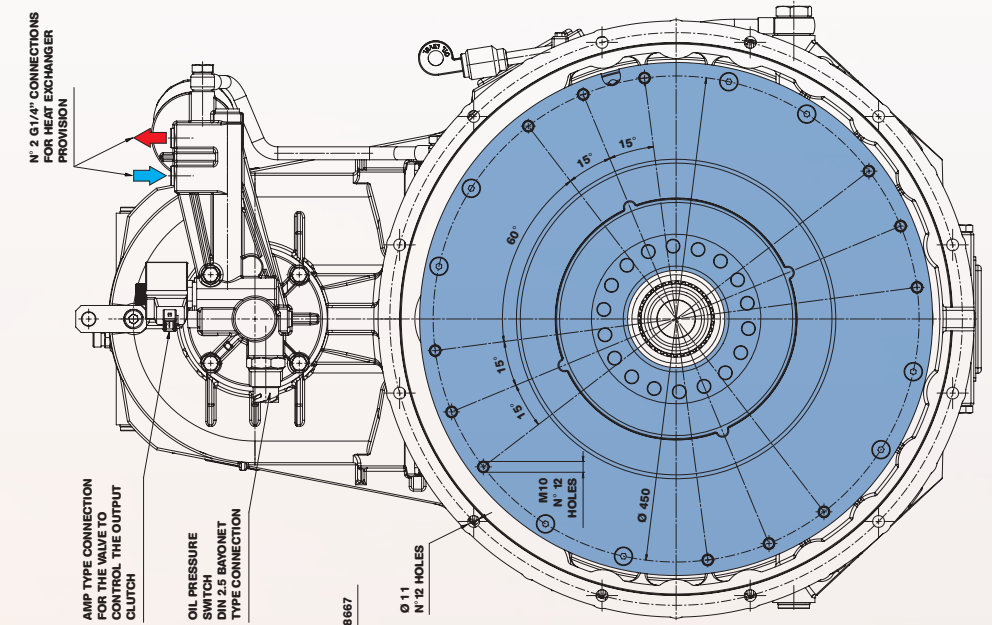

FRONT VIEW

VEHICLE MOTION DIRECTION

REAR VIEW (12 O'CLOCK)