

Dimensions

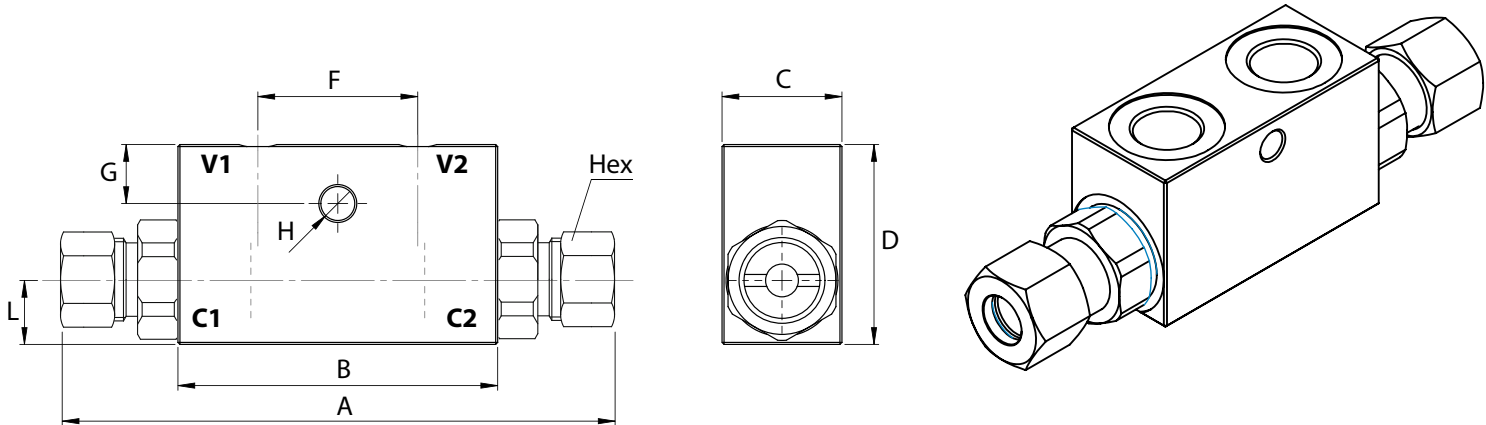

Size	A	B	C	D	V1-V2 BSP	C1-C2	F	G	H	L	Hex	Weight kg
01	138	68	30	40	1/4	12	38	7	7	13	22	0,65
15	138	68	30	40	3/8	12	38	7	7	13	22	0,62
02	138	80	30	50	3/8	15	40	15	8,5	16	27	0,95
25	138	80	30	50	1/2	15	40	15	8,5	16	27	0,90

Hydraulic Symbol

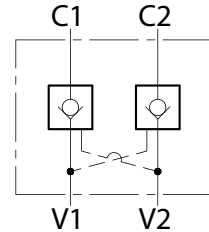

Curves

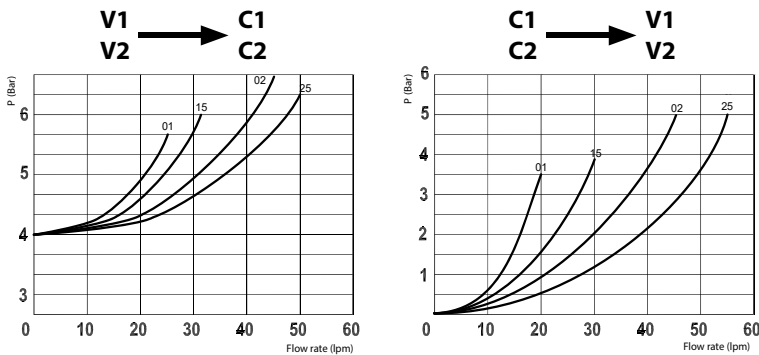

Features

Size	01	15	02	25
Max Pressure(bar)	350	350	300	300
Max Flow(lpm)	25	30	45	50
Pilot Ratio	1:4.6	1:4.6	1:4	1:4
Cracking Pressu(bar)	4	4	4	4

Materials: Zinc plated steel body, hardened steel inner parts.

Ordering Code

LVDT-DIN --

	Size BSP
01	1/4
15	3/8
02	3/8
25	1/2

Ordering Code Example: LVDT-DIN15 = 3/8 BSP - DIN2353 12L ported, 30 lpm.