

Dimensions

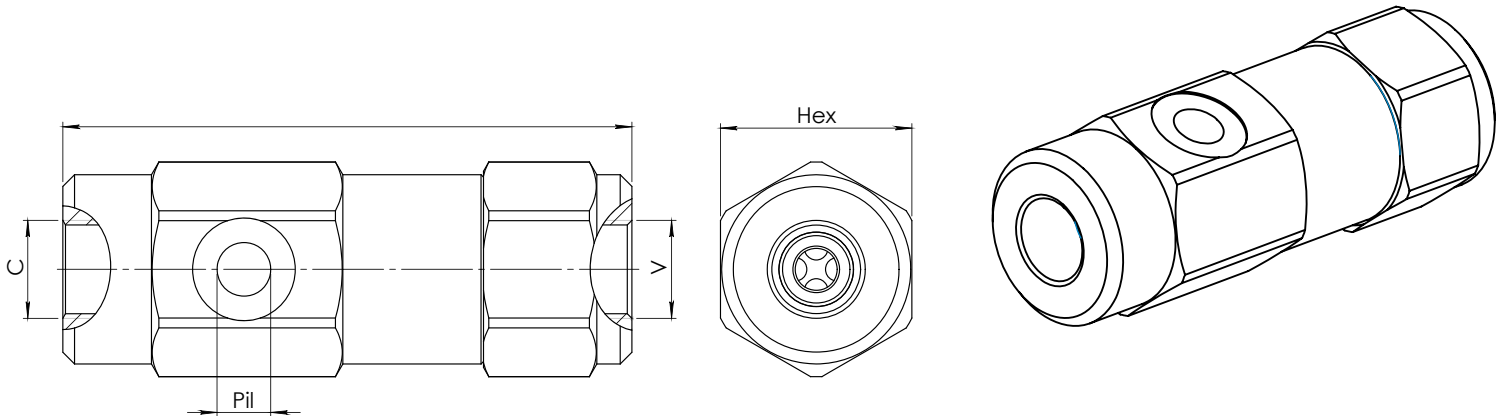

Size	A	C - V BSP	Pil BSP	Hex	Weight kg
01	103	1/4	1/4	36	0,71
02	112	3/8	1/4	40	0,98
03	122	1/2	1/4	42	1,09
04	145	3/4	1/4	55	2,32
05	164	1	1/4	55	2,44

Hydraulic Symbol

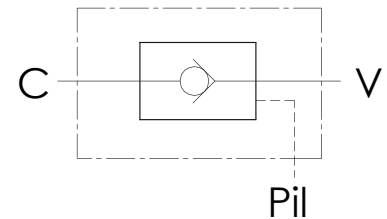

Curves

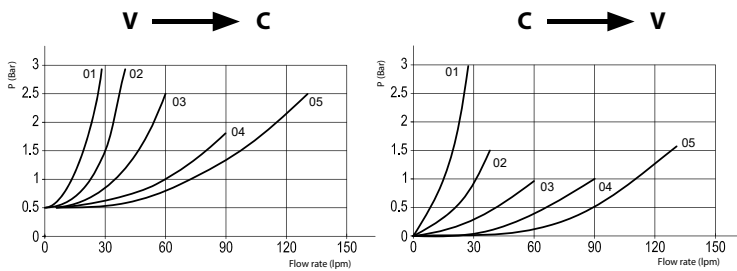

Features

Size	01	02	03	04	05
Max Pressure (bar)	350	350	350	300	260
Max Flow (lpm)	25	40	60	90	130
Pilot Ratio	1:9,4	1:6,2	1:4,2	1:4,4	1:3,5
Cracking Pressure (bar)	0,5	0,5	0,5	0,5	0,5

Materials: Zinc plated steel body, hardened steel inner parts.

Ordering Code

LVPL **--**

	Size BSP
01	1/4
02	3/8
03	1/2
04	3/4
05	1

Ordering Code Example: LVPL03 = 1/2 BSP.